

CABLE TYPE CURRENT TRANSFORMERS



**CABLE TYPE
CURRENT TRANSFORMERS**

01

TECHNICAL INFORMATION

02/03/04

PRODUCT OVERVIEW
KATK-85/98 & KAT-85/98 TYPES

05

TECHNICAL INFORMATION

06/07

PRODUCT OVERVIEW
KAT-60, KAT-130, KAT-180 TYPES

08/09

PRODUCT OVERVIEW
SAA-120 SPLIT CORE CABLE TYPE

APPLICATIONS

KAT, KATK and SAA cable type transformers;

are used for metering and protection purposes. Max.operating voltage is 0.72 kV. They can be used with fully insulated cables on all voltage level.

Secondary terminals

One of the secondary terminals should be earthed for safety.

Secondary winding of a current transformer must not be operated with an open circuit. It should be connected measuring devices before application of primary connection as seen in **figure-1**. The secondary winding of current transformer which will not be used must always be short-circuited and earthed as seen in **figure-2**.

For the transformer with reconnectable and/or tapped secondaries, unused terminals must be left open as seen in **figure 3**.

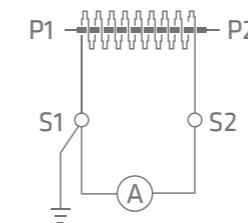

figure-1

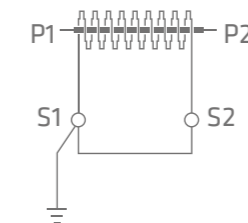

figure-2

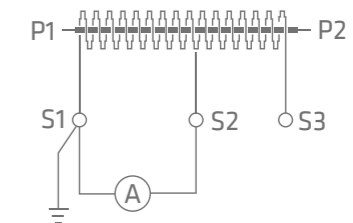

figure-3

If cable type current transformers will be assembled on to isolated HV cable, shielded cable should be earthed as seen on **figure-4** to be able to prevent effects caused by the possible leakage current flow on measuring systems.

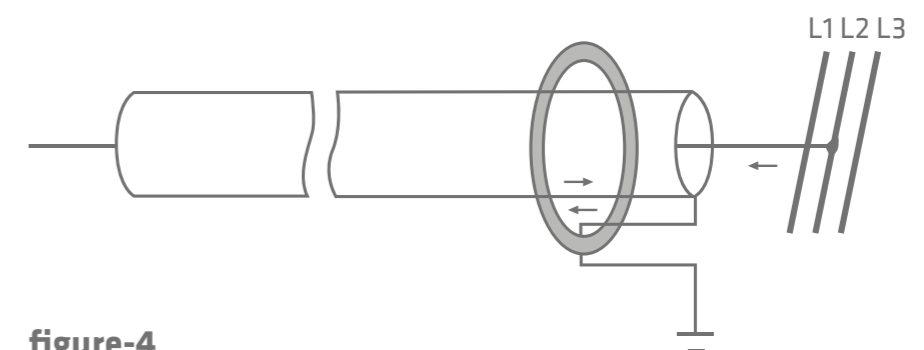

figure-4

KATK-85/98



* KATK-85/98
Reference:110027



* KATK-85/98
Reference:120102



* with secondary terminal
Reference:120103

KATK cable type transformers are used for metering and protection purposes.

Max. operating voltage is 0,72 kV.

They can be used with fully insulated cables on all voltage levels. Those are maintenance free products on the operation.

KATK cable type transformers have two different kind of base plate that allows mounting in any position.

Up to 4 secondary cores.

On request with cable or secondary terminal output.

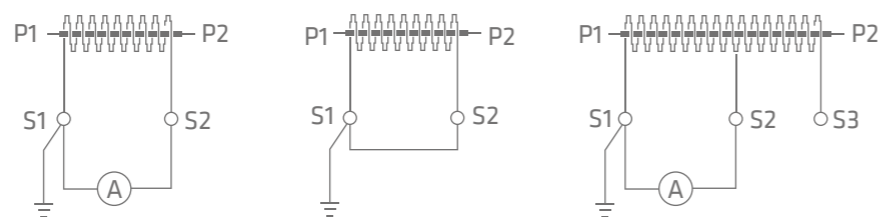

120103

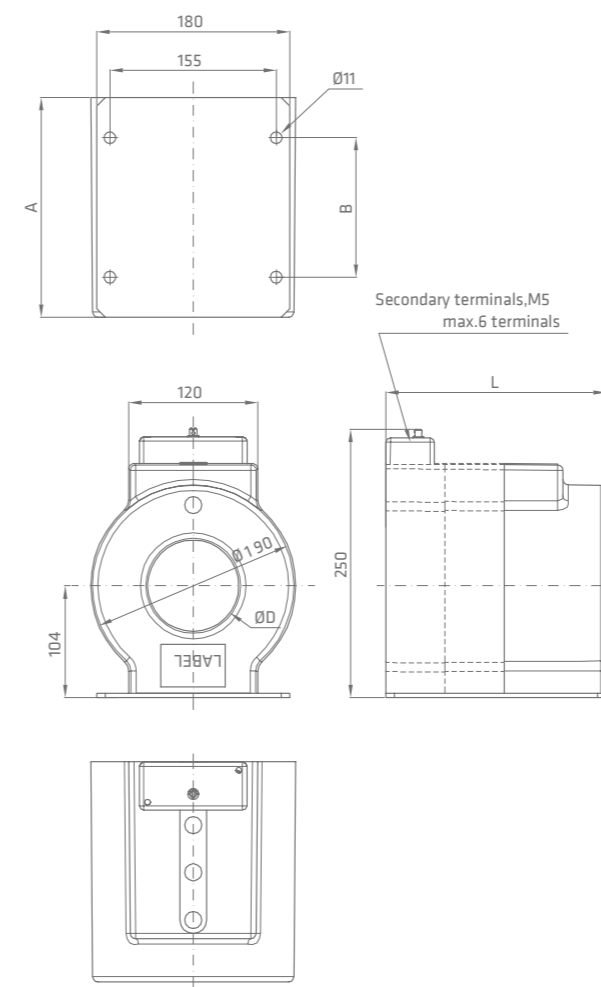

with secondary terminal

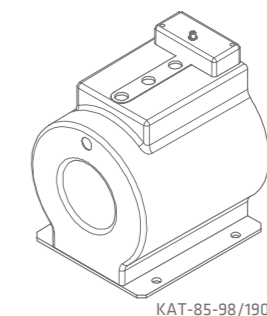

KAT-85-98/190-205

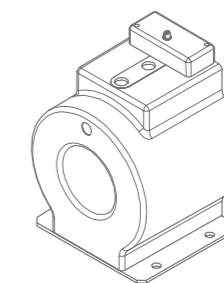

KAT-85-98/190-150

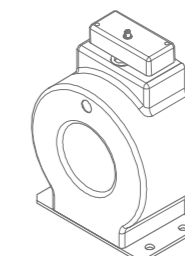

KAT-85-98/190-95

NO	øD	L	A	B	TYPE
1	85	95	95	50	KAT-85/190-95
2	85	150	150	75	KAT-85/190-150
3	85	205	205	130	KAT-85/190-205
4	98	95	95	50	KAT-98/190-95
5	98	150	150	75	KAT-98/190-150
6	98	205	205	130	KAT-98/190-205

TECHNICAL DATA

TECHNICAL DATA	
Rated primary current I_{pr}	40-2000 A
Rated secondary current I_s	1A, 5A
Rated frequency	50 Hz, 60Hz
Class rated burden	1 - 30 VA
Accuracy class	0,2S, 0,5S, 0,2, 0,5, 1, 5P, 10P
Insulation level	0,72/3/ -kV
Rated short time thermal current (I_{th})	$100 \times I_n$
Insulation class	E
Standard	IEC, ANSI, VDE, AS, CAN, GOST, etc

DIMENSIONS

110027

with cable output

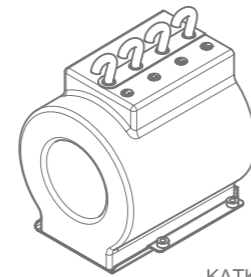
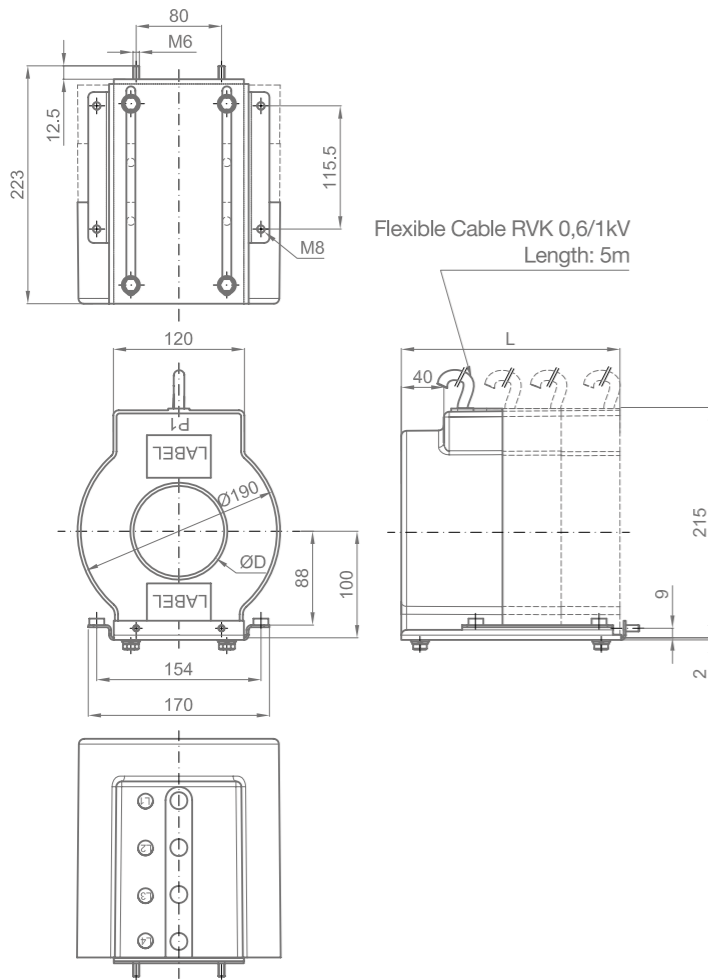

KATK-85-98/190-205

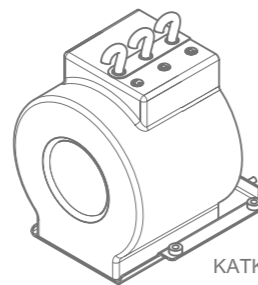

KATK-85-98/190-150

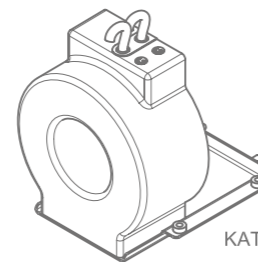

KATK-85-98/190-95

NO	øD	L	TYPE
1	85	95	KATK-85/190-95
2	85	150	KATK-85/190-150
3	85	205	KATK-85/190-205
4	98	95	KATK-98/190-95
5	98	150	KATK-98/190-150
6	98	205	KATK-98/190-205

	1A	5A
1 Primary and 1 Secondary	2x2.5mm ² S1-Black, S2-Brown	2x4mm ² S1-Black, S2-Brown
2 Primary and 1 Secondary	3x2.5mm ² S1-Black, S2-Brown, S3-Grey	3x4mm ² S1-Black, S2-Brown, S3-Grey
1 Primary and 2 Secondary	2x(2x2.5mm) ² 1S1-Black, 1S2-Brown, 2S1-Black, 2S1-Brown	2x(2x4mm) ² 1S1-Black, 1S2-Brown, 2S1-Black, 2S1-Brown
2 Primary and 2 Secondary	2x(3x2.5mm) ² 1S1-Black, 1S2-Brown, 1S3-Grey 2S1-Black, 2S2-Brown, 2S3-Grey	2x(3x4mm) ² 1S1-Black, 1S2-Brown, 1S3-Grey 2S1-Black, 2S2-Brown, 2S3-Grey
2 Primary and 3 Secondary	3x(3x2.5mm) ² 1S1-Black, 1S2-Brown, 1S3-Grey 2S1-Black, 2S2-Brown, 2S3-Grey 3S1-Black, 3S2-Brown, 3S3-Grey	3x(3x4mm) ² 1S1-Black, 1S2-Brown, 1S3-Grey 2S1-Black, 2S2-Brown, 2S3-Grey 3S1-Black, 3S2-Brown, 3S3-Grey

APPLICATIONS



KAT, KATK and SAA cable type transformers; are used for metering and protection purposes. Max. operating voltage is 0.72 kV. They can be used with fully insulated cables on all voltage level.

Secondary terminals

One of the secondary terminals should be earthed for safety. Secondary winding of a current transformer must not be operated with an open circuit. It should be connected measuring devices before application of primary connection as seen in **figure-1**. The secondary winding of current transformer which will not be used must always be short-circuited and earthed as seen in **figure-2**. For the transformer with reconnectable and/or tapped secondaries, unused terminals must be left open as seen in **figure 3**.

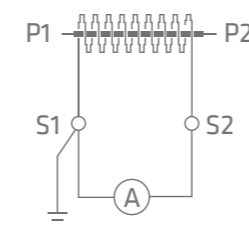

figure-1

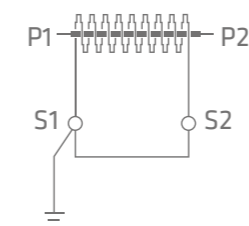

figure-2

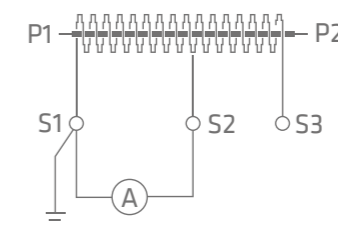

figure-3

If cable type current transformers will be assembled on to isolated HV cable, shielded cable should be earthed as seen on **figure-4** to be able to prevent effects caused by the possible leakage current flow on measuring systems.

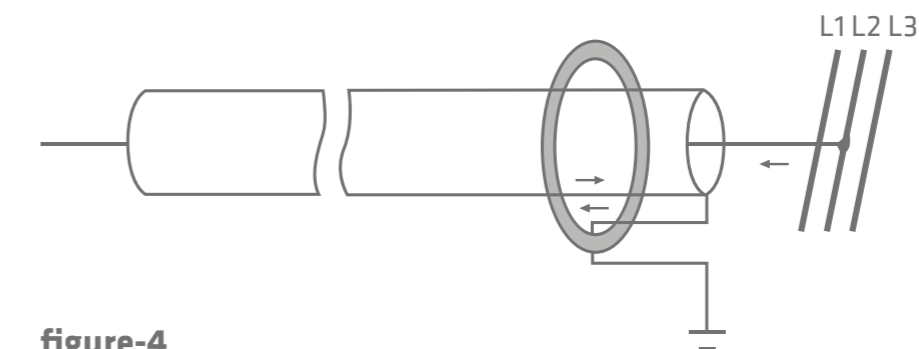
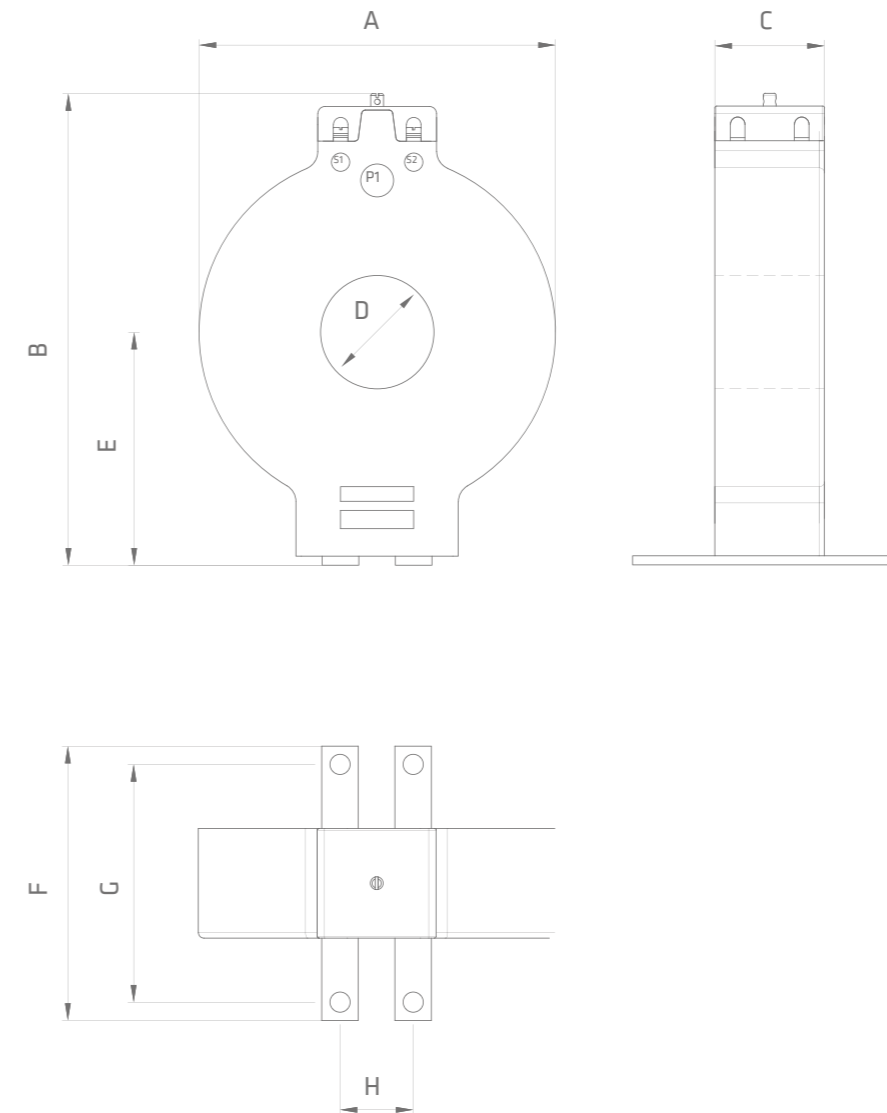

figure-4

DIMENSIONS



Type	A ±2	B ±2	C ±1	D ±1	E ±2	F ±1	G ±1	H ±1
KAT-60/195-100	195	259	100	62	127,5	150	130	40
KAT-60/250-120				62				
KAT-130/250-120	247	318	120	130	160	180	160	60
KAT-180/250-120				180				

Rated primary current I_{pr} [A]	20.....8000A
Rated secondary current I_s (A)	1A, 5A
Rated frequency	50Hz, 60Hz
Class rated burden [VA]	Acc. to customer requirement
Accuracy class	Acc. to customer requirement
Insulation level	0,72 / 3 / - kV
Rated short time thermal current [I_{th}]	min. $100 \cdot I_{pr}$
Insulation class	E
Standard	IEC, VDE, ANSI, AS, CAN, GOST, etc.

ASSEMBLY

Split Core Current Transformers have a magnetic circuit which is splitted two parts and its max. operating voltage is 0.72 kV with non-insulated busbars. However they can be used with fully insulated cables on all voltage level. These transformers can be assembled to the system without any power interruption and without the need of demounting any conductor.

These transformers are used for measuring and protection.

Moreover; they are used for special applications such as measurement of leakage current with precision cores which have high magnetic permeability.

SAA For Measuring Earth Leakage

Nominal Current 50A - 100A.

SAA For Measuring Earth Leakage transformers have high permeability cores. They are suitable for measuring earth leakage current at three phase networks. At well designed three phase network, any of three phase current's vectorial sum is zero.

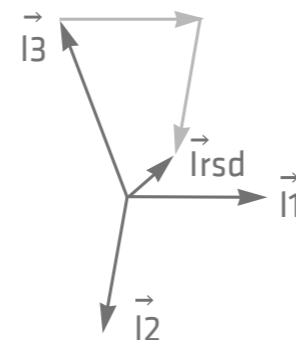

$$\vec{I}_{dsd} = 3 \cdot I_0 = I_1 + I_2 + I_3$$

In case of an earth leakage the balance of the current in cable is disrupted and the resultant earth leakage current excites the transformer. Depending on the measurement procedure of the earth fault currents, either a secondary current or a voltage transformer simply actuates earth fault detectors and/or relays.

DIMENSIONS

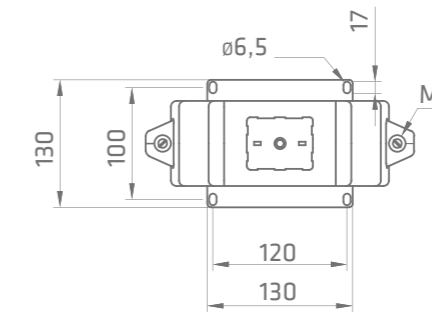
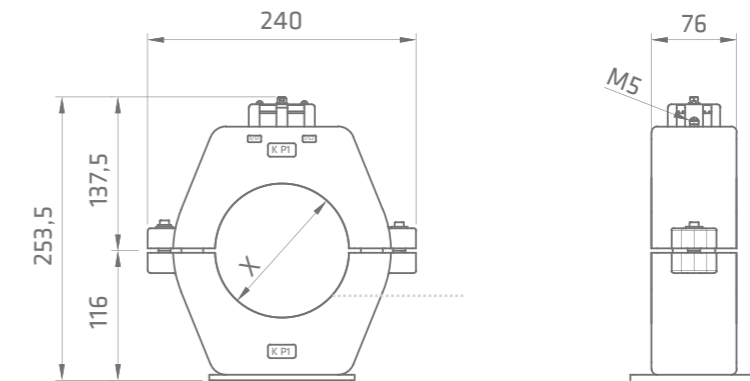

Type	X(mm)
SAA-120	120

TECHNICAL DATA

Rated primary current I_{pr} [A]	50...2500A
Rated secondary current I_s (A)	1A, 5A
Rated frequency	50Hz, 60Hz
Rated Class Burden	Acc. to customer requirement
Accuracy Class	Acc. to customer requirement
Insulation Class	0,72 / 3 / - kV
Rated Short Time Current	min. $100 \cdot I_{pr}$
Insulation Class	E
Standard	IEC, VDE, ANSI, AS, CAN, GOST, etc.



ALCE Elektrik Sanayi ve Ticaret A.Ş.
Ramazanoğlu Mah. Transtek Cad. No: 6
Pendik 34906 İstanbul, TURKEY
T +90-216-585 42 00 F +90-216-378 23 27
www.alce-elektrik.com.tr | info@alce-elektrik.com.tr

